

# PULKRA

WWW.PULKRA.IT



MANIFESTO 2.4  
BY STORMO STUDIO  
MADE WITH ACRON®

240

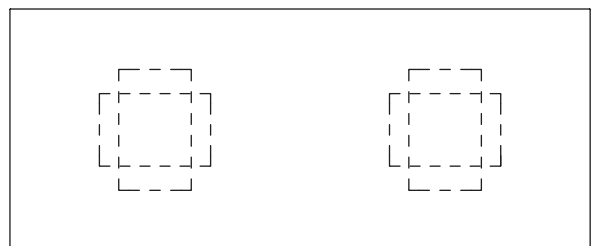

100

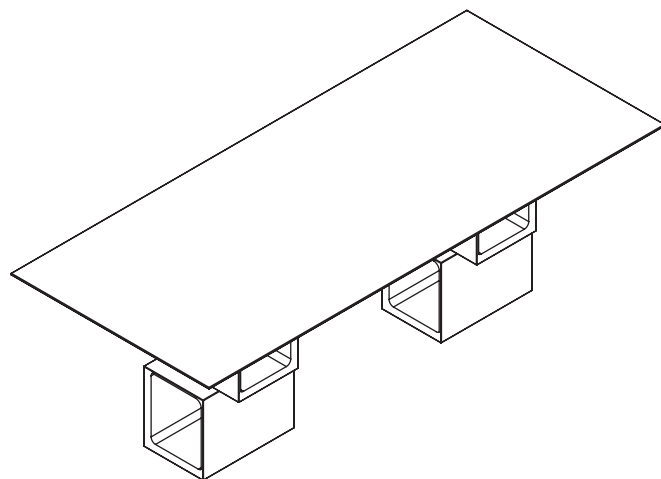

240

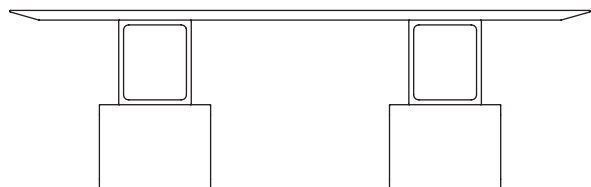

74

30  
46

SKU

MNFST. 24

MISURE/SIZE

240 X 100 X H. 74

FINITURE/ FINISHES

BLACK, WHITE, ORIGIN, SOUL, RED, DESIRE, HOPE  
MEMORY, TIME, PURE, MIND, LIFE

PESO/WEIGHT

232 KG

COLLI/PACKAGE

5

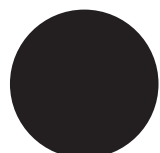

BLACK

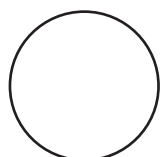

WHITE



ORIGIN  
NCS S 0530-G80Y

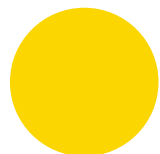

SOUL  
RAL 1018



RED  
NCS S 1085-Y80R

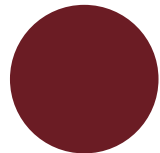

DESIRE  
RAL 3004

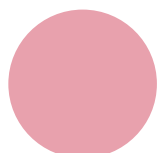

HOPE  
NCS S 0520-R10B

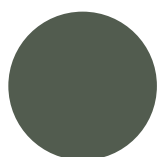

MEMORY  
RAL 7009

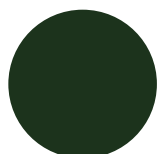

TIME  
RAL 6009

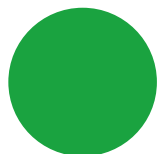

PURE  
RAL 6037

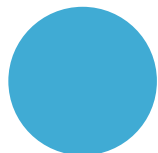

MIND  
NCS S 1050-B

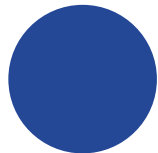

LIFE  
RAL 5002

---

La ricerca progettuale di Stormo Studio è accompagnata costantemente dal background comune nell'ambito dell'architettura. Elena Calabrò e Michael Carion indagano l'intrinseca relazione tra spazio e materia e ricercano la fisicità nelle emozioni, lasciando che la forma risultante da questo processo sia naturalmente evocativa e significativa. Stimolati dalle potenzialità del cemento come materiale di design e cercando di sfidare la materia sino al suo limite, hanno progettato Manifesto. La collezione è ispirata alle teorie architettoniche del Metabolismo, riferendosi poi a temi ricorrenti della pratica progettuale dello studio come l'estetica del vuoto e la filosofia orientale. Manifesto si compone di tavoli in diverse dimensioni e configurazioni, caratterizzati da sostegni all'apparenza massicci, ma che in realtà si basano su un equilibrio delicato. Una sfida tecnica che ben rappresenta ricerca di Pulkra.

*Everything Stormo Studio creates is informed by the designers' shared background in architecture. Elena Calabrò and Michael Carion investigate the intrinsic relationship between space and material and seek physicality in emotions, letting the form resulting from this process be naturally meaningful and evocative. Manifesto is inspired by the potential the pair saw in concrete and the challenge of seeing how far they could take it. The collection echoes the architectural theories of Metabolism, while incorporating some of the studio's recurring themes such as the aesthetics of the void and Oriental philosophy. Manifesto's tables, in different sizes and configurations, appear to rest on massive supports but in truth feature a delicate balance. A technical challenge, met by none other than Pulkra.*

# PULKRA

WWW.PULKRA.IT



MONTAGGIO/ASSEMBLY

Si consiglia di far eseguire il montaggio a personale qualificato. Per la movimentazione delle basi sono necessarie 2 persone, per il piano 4-6 persone. Attenzione, durante la movimentazione del prodotto, onde evitare di danneggiare il prodotto, si consiglia di appoggiare sempre i diversi elementi su una superficie protettiva e di non piegare bruscamente il piano. Durante il montaggio, maneggiare il prodotto con guanti puliti.

*We recommend having the assembly carried out by qualified personnel. 2 people are needed to move the bases, 4-6 people are needed for the top. Attention, when moving the product, to avoid damaging the product, we recommend always placing the various elements on a protective surface and not bending the top abruptly. During assembly, handle the product with clean gloves.*

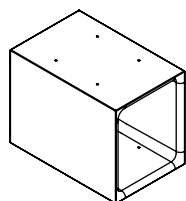

X4 BASE MODULE



X8 ADESIVE  
RUBBER PADS

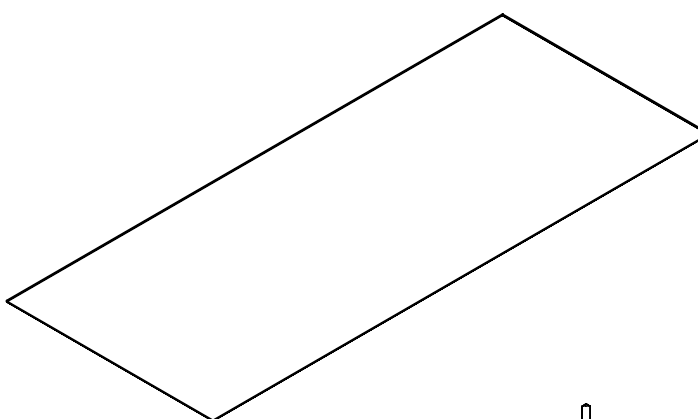

X1 TABLE TOP



X16 SCREWS

# 1

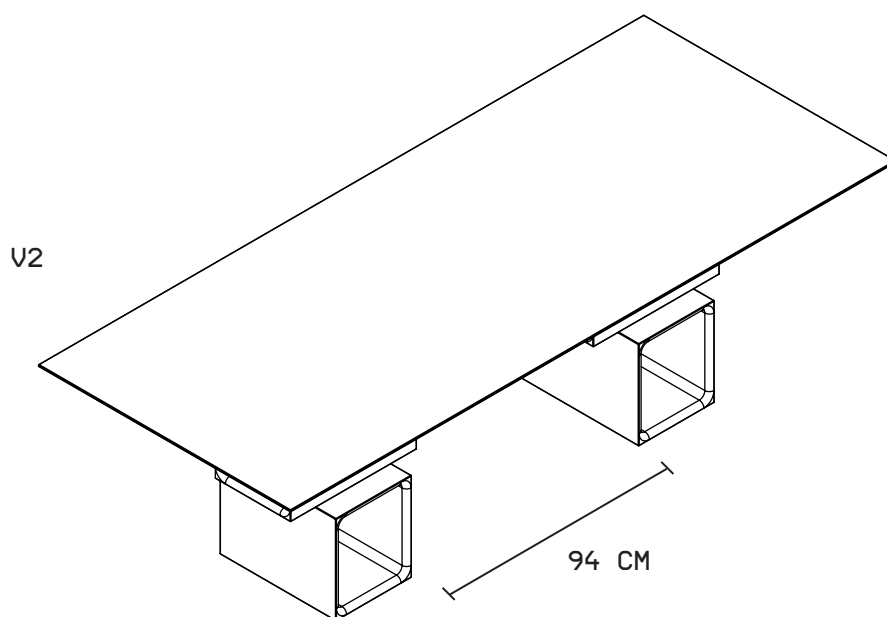
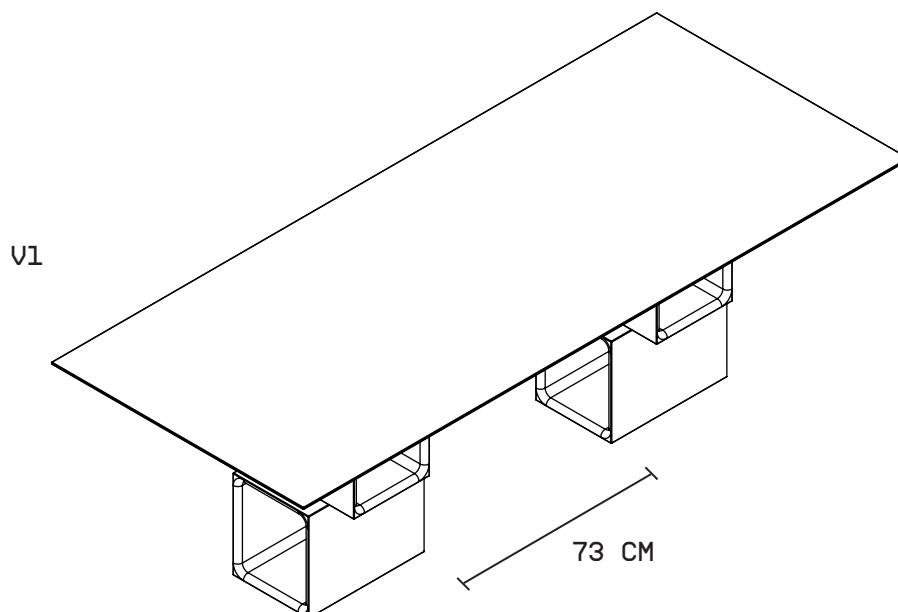

IT • LE BASI POSSONO ESSERE POSIZIONATE IN DUE MODI ANALOGHI. SCEGLIERE PRIMA DEL MONTAGGIO COME ORIENTARE LE BASI, SE ORTOGONALI O PARALLELE AL PIANO DEL TAVOLO. NEL CASO SI SCELGA LA VARIANTE 1, POSIZIONARE LA BASI INFERIORI AD UNA DISTANZA DI 73 CM. NEL CASO SI SCELGA LA VARIANTE 2, POSIZIONARE LA BASI INFERIORI AD UNA DISTANZA DI 94 CM.

EN • THE BASES CAN BE POSITIONED IN TWO SIMILAR WAYS. BEFORE ASSEMBLY, CHOOSE HOW TO ORIENT THE BASES WHETHER ORTHOGONAL OR PARALLEL TO THE TABLE TOP. IF YOU CHOOSE VARIANT 1, POSITION THE LOWER BASES AT A DISTANCE OF 73 CM. IF YOU CHOOSE VARIANT 2, POSITION THE LOWER BASES AT A DISTANCE OF 94 CM.

---

## 2

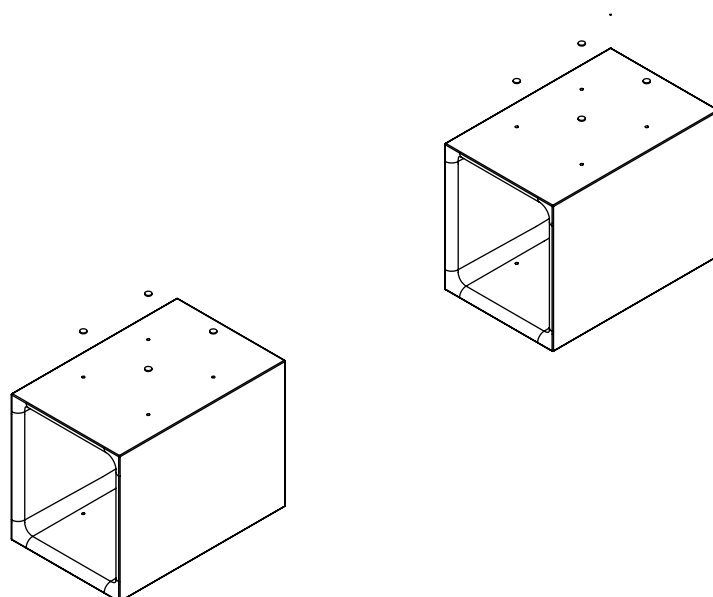

---

IT • RUOTARE LE BASI INFERIORI ED APPLICARE I GOMMINI PROTETTIVI.

EN • ROTATE THE LOWER BASES AND APPLY THE PROTECTIVE RUBBERS PADS.

---



---

3

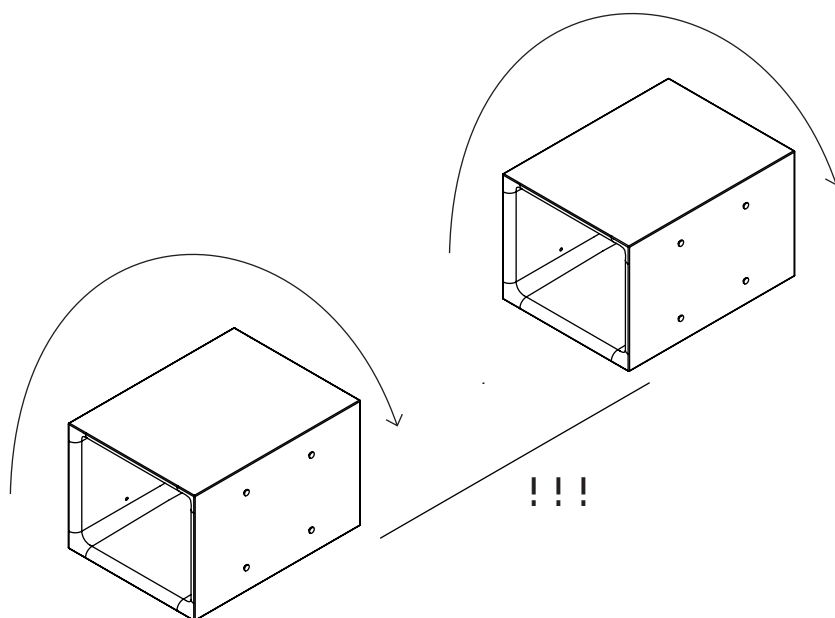

---

IT • RUOTARE NUOVAMENTE LA BASE INFERIORE NELLA POSIZIONE CORRETTA, AVENDO CURA DI MANTENERE LA DISTANZA CORRETTA COME DA INDICAZIONE 1.

EN • ROTATE THE LOWER BASE AGAIN TO THE CORRECT POSITION, TAKING CARE TO MAINTAIN THE CORRECT DISTANCE AS PER INDICATION 1.

---

---

4

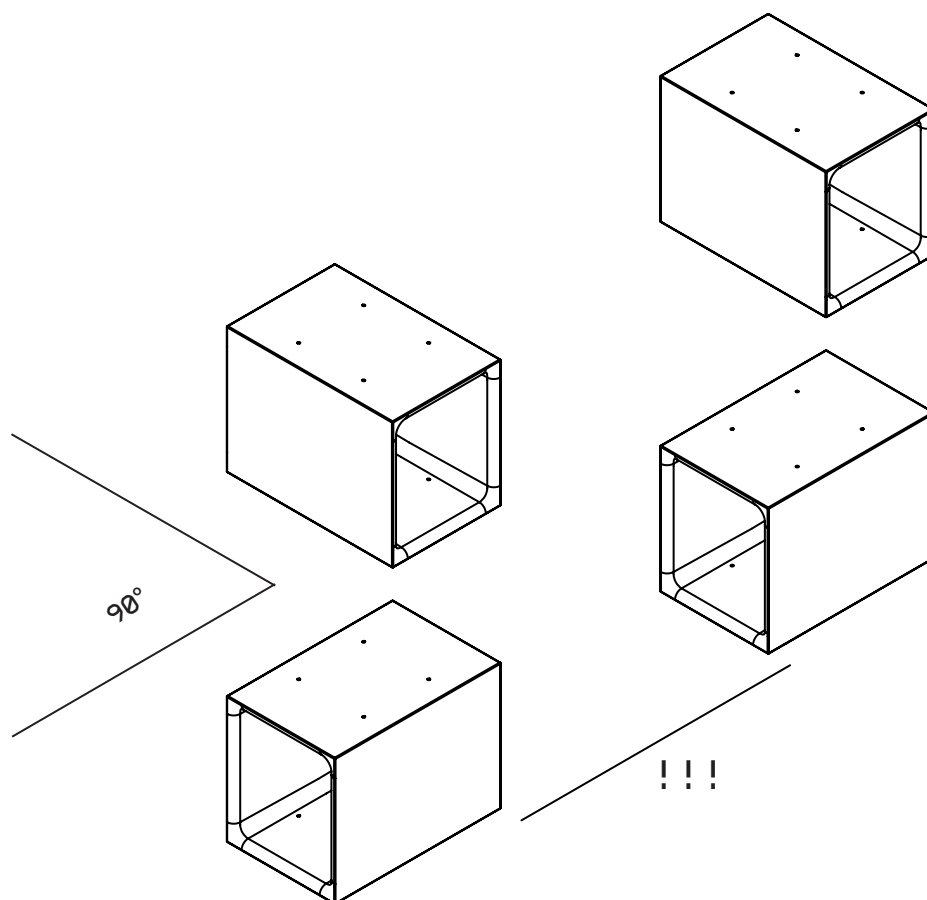

---

IT • POSIZIONARE LE BASI SUPERIORI A 90 GRADI RISPETTO QUELLE INFERIORI COME INDICATO.

EN • POSITION THE UPPER BASES AT 90 DEGREES TO THE LOWER ONES AS INDICATED.

---

---

5

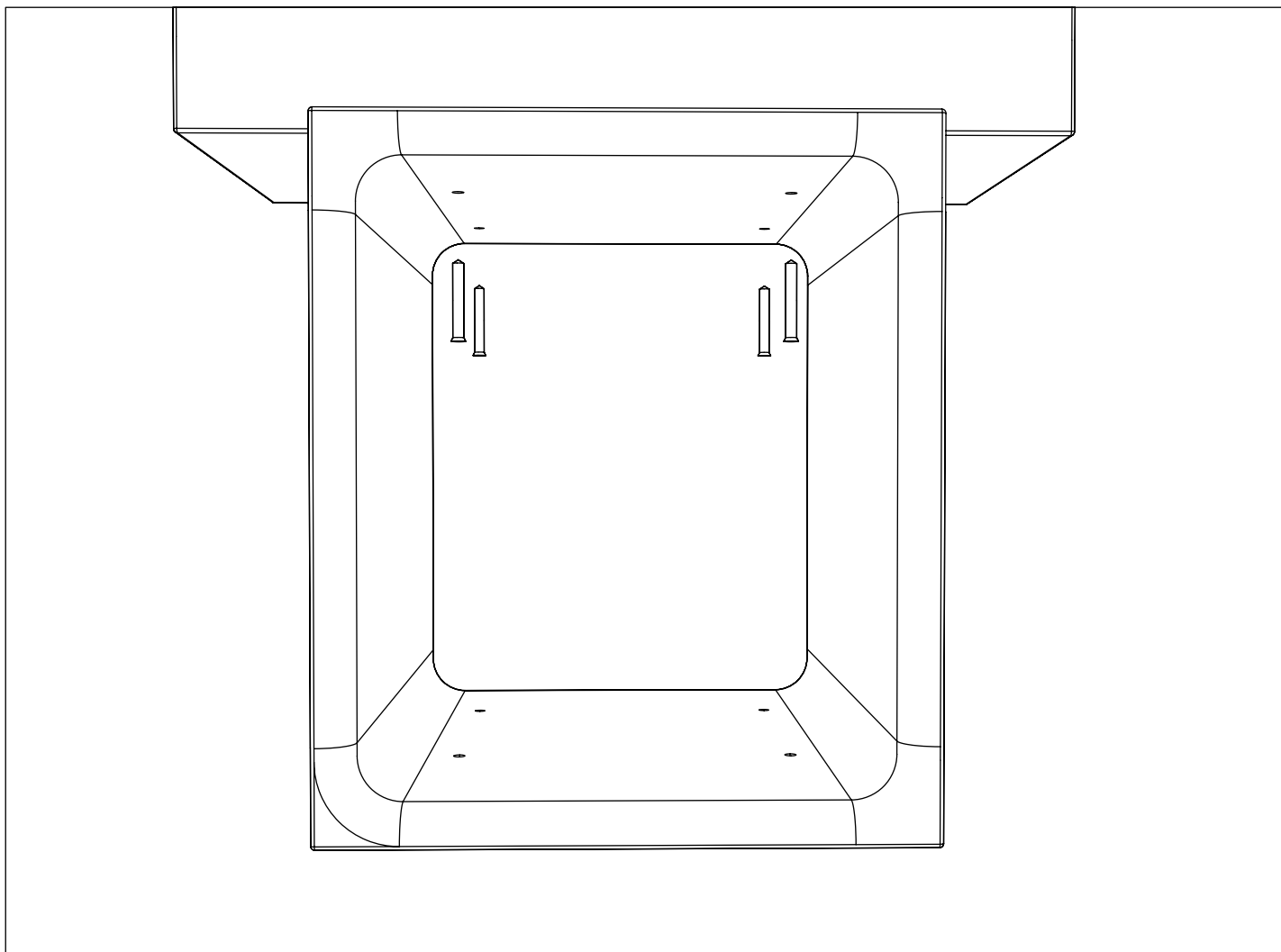

---

IT • INSERIRE LE VITI NEI FORI DELLE BASI INFERIORI ED AVVITARE.

EN • INSERT THE SCREWS INTO THE HOLES IN THE LOWER BASES AND TIGHTEN.

---

---

6

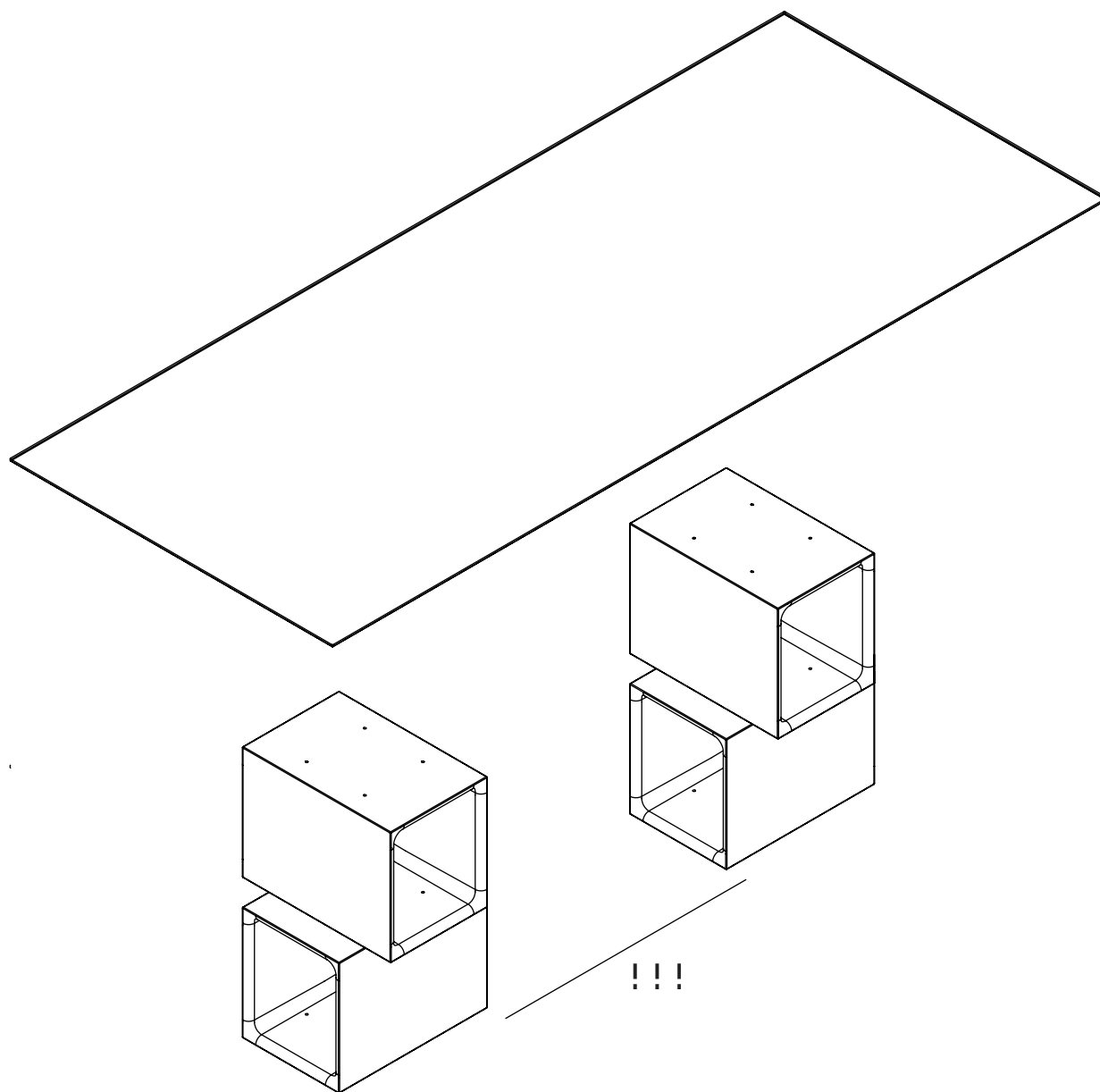

---

IT • CON ESTREMA CAUTELA POSIZIONARE IL PIANO SULLE BASI.

EN • PLACE THE TOP ON THE BASES WITH EXTREME CAUTION.

---

---

7

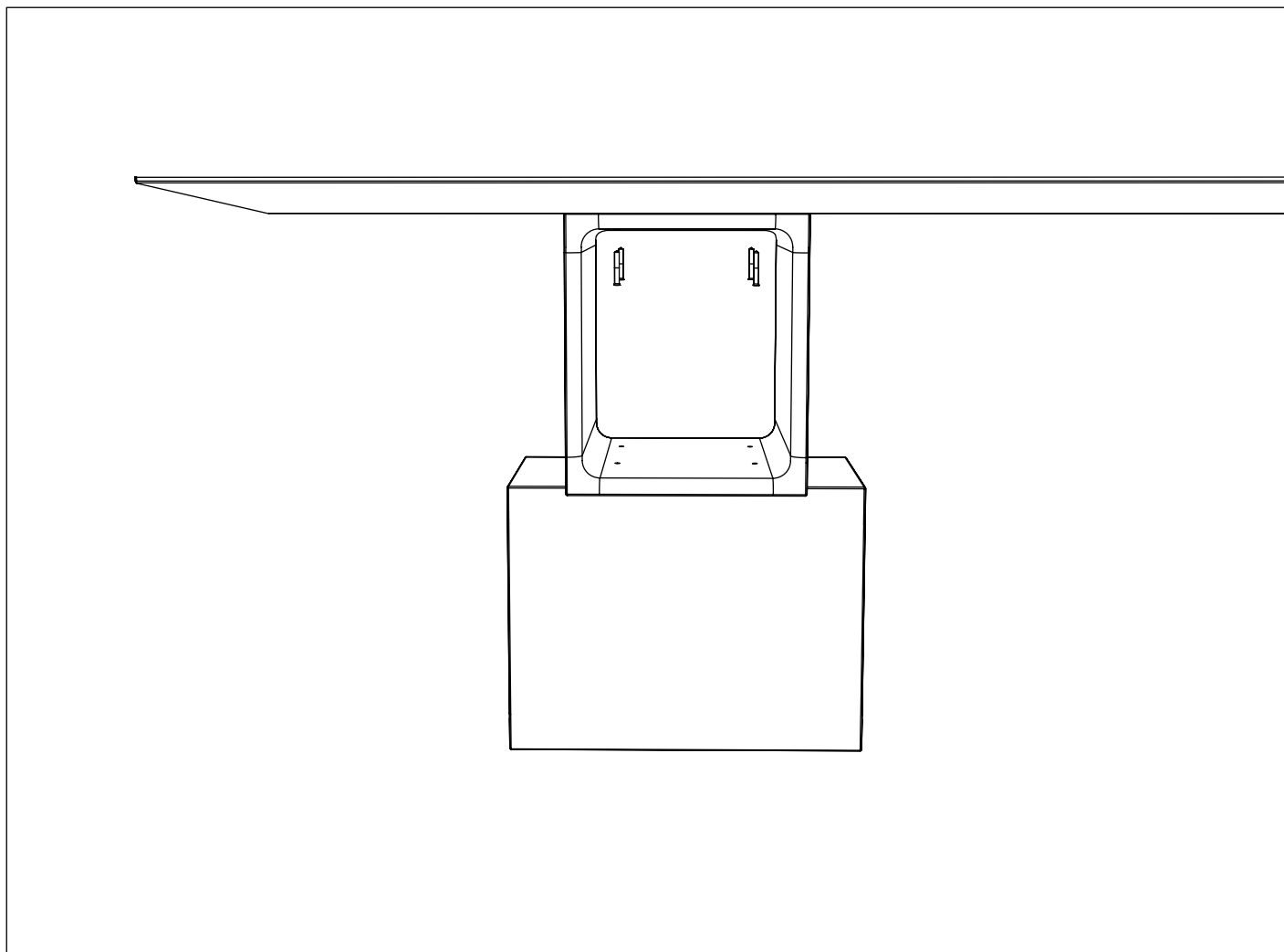

---

IT • INSERIRE LE VITI NEI FORI DELLE BASI SUPERIORI ED AVVITARE. ORA IL TAVOLO È FRUIBILE.

EN • INSERT THE SCREWS INTO THE HOLES IN THE UPPER BASES AND TIGHTEN. NOW THE TABLE IS USABLE.

---

---

8

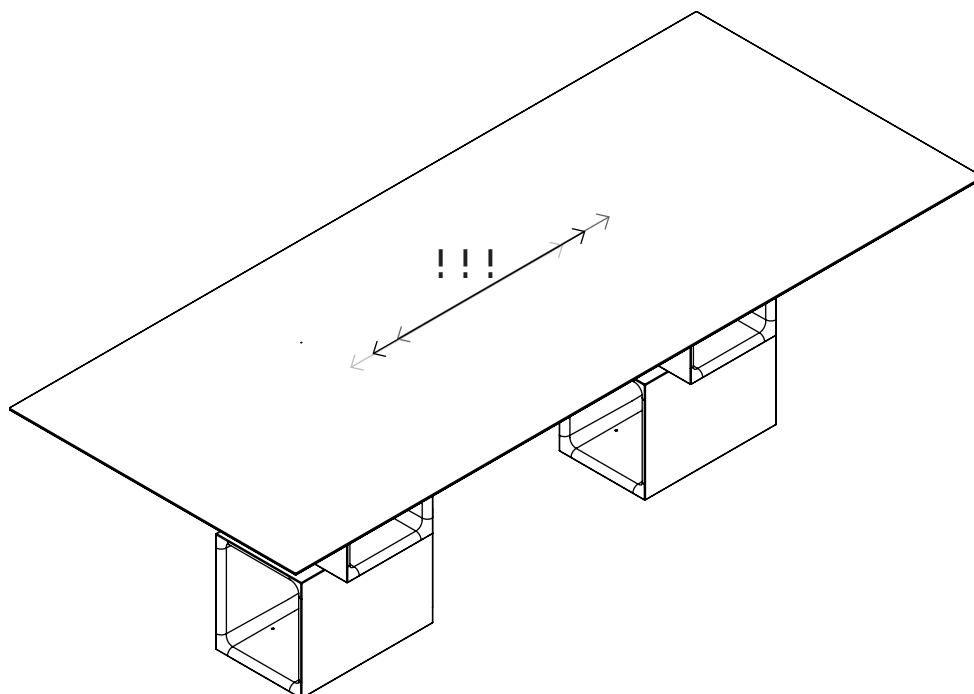

---

IT • QUALORA IL TAVOLO DEVE ESSERE SPOSTATO DOPO L'ASSEMBLAGGIO SI CONSIGLIA FERMAMENTE DI SMONTARE IL PIANO DALLE BASI, RISPOSIZIONARE LA BASI CORRETTAMENTE ED AVVITARE NUOVAMENTE IL PIANO IN POSIZIONE, PER EVITARE DI SFORZARE ECCESSIVAMENTE GLI ALLOGGIAMENTI DELLE VITI.

EN • IF THE TABLE MUST BE MOVED AFTER ASSEMBLY, IT IS STRONGLY RECOMMENDED TO DISMANTLE THE TOP FROM THE BASES, REPOSITION THE BASES CORRECTLY AND SCREW THE TOP BACK INTO POSITION, TO AVOID EXCESSIVELY STRAINING THE SCREW SLOTS.

---

---

Se dovessi avere problemi nell'assemblare il tuo prodotto, contattaci all'indirizzo [info@pulkra.it](mailto:info@pulkra.it). Siamo sempre felici di aiutarti!

Abbiamo selezionato attentamente i materiali utilizzati in questo prodotto e ti chiediamo di trattarlo con responsabilità. Ti preghiamo di riciclare tutto l'imballaggio secondo le norme locali di smaltimento.

*Should you have any problems assembling your product contact us at [info@pulkra.it](mailto:info@pulkra.it). We're always happy to help! We have carefully selected the materials used in this product, and ask you to treat it responsibly too. Please recycle all packaging according to your local disposal rules.*